

F93 Series Air Volume Controls for Deep Wells

Product/Technical Bulletin

Part No. 24-7664-3000, Rev. A
Issued October 2018

Refer to the [QuickLIT website](#) for the most up-to-date version of this document.

The F93 Series Air Volume Controls for Deep Wells control the amount of air in the residential water storage tanks of deep well water systems. Deep wells are more than 25 ft (7.6 m) deep.

F93 Series Controls automatically maintain air volume in the storage tanks of deep well water systems by allowing air to escape from the tank and into the surrounding room when the water level in the tank drops (increase of air volume).

F93 deep well controls open the air valve on a fall in tank water level to bleed excess air from the tank at pressures up to 100 psig (690 kPa).

The F93H has a minimum pressure release valve to avoid lowering tank pressure below 25 psig (172 kPa). Use this model on applications where water may be rapidly drained.



Figure 1: F93B Air Volume Control for Deep Wells

Table 1: Features and benefits

Features	Benefits
Sturdy Noryl (high performance thermoplastic) body	Resists mechanical damage and corrosion.
Brass internal operating parts	Minimize corrosion.
Pressure tested plastic float	Provides long operating life.
Optional pressure gauge tapping	Allows mounting of a pressure gauge.
Certification for Federal Safe Drinking Water Act	Meets the US Federal standards of the Reduction of Lead in Drinking Water Act.



Application

IMPORTANT: Use this F93 Series Air Volume Control for Deep Wells only as an operating control. Where failure or malfunction of the F93 Series Air Volume Control could lead to personal injury or property damage to the controlled equipment or other property, additional precautions must be designed into the control system. Incorporate and maintain other devices, such as supervisory or alarm systems or safety or limit controls, intended to warn of or protect against failure or malfunction of the F93 Series Air Volume Control.

Water storage tanks in residential water systems rely on a volume of air in the tank to provide system pressure, making it important to control the amount of air in the tank:

- Too little air in the tank results in rapid pump cycling - a problem common in shallow well systems (less than 25 ft [7.6 m] deep).
- Too much air in the tank results in air entering the distribution system - a problem common in deep well systems (more than 25 ft [7.6 m] deep).

For information on air volume controls for shallow wells, refer to the *F92 Series Air Volume Controls for Shallow Wells Product/Technical Bulletin* (Part No. 24-7664-2993).

Installation

IMPORTANT: Use only Teflon® thread sealing tape or pipe sealant that is compatible with plastic. Pipe sealant meant for use with metal may corrode the plastic body, causing it to crack.

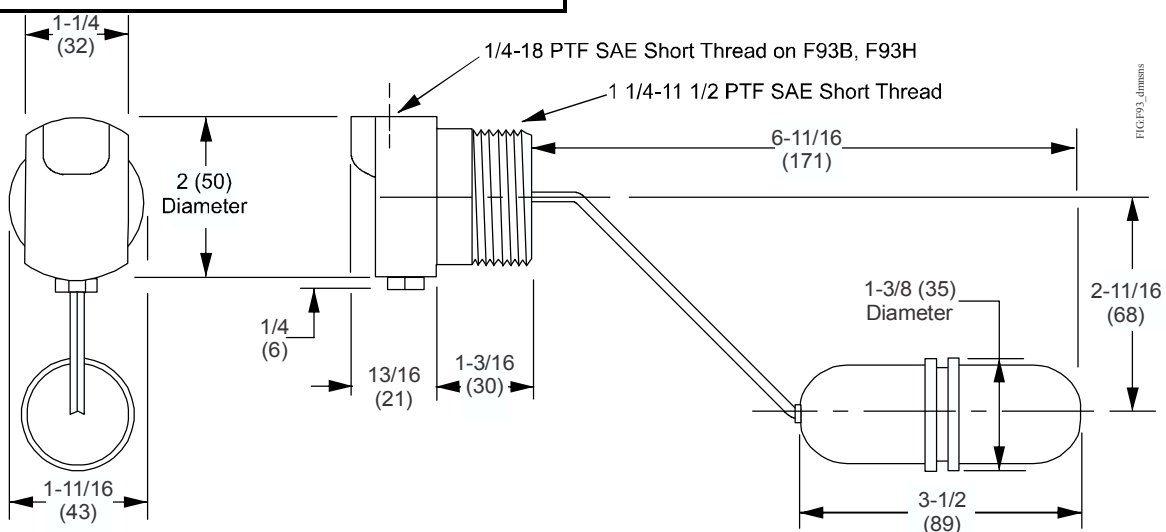

Figure 2: F93 Series Air Volume Control for Deep Wells Dimensions, in. (mm)

Install the control in the tank as follows:

1. If you are using Teflon® thread sealing tape, wrap the 1-1/4 in. NPT threads on the control. Overlap the tape half its width to make two layers, and continue to where the thread ends at the large end. If you are using pipe sealant instead of Teflon tape, apply a generous amount of sealant to the male threads.
2. Using a wrench on the flat sides of the control body, screw the control into a tank opening located about 2/3 of the way up.

Note: The tank must have a diameter of at least 9 in. (229 mm) to allow room for the float to operate.

IMPORTANT: Tighten (not overly tight) with the air valve and assembly pointed down. Ensure that the wrench does not slip and damage the air valve casing assembly.

F93B and F93H models

The F93B and F93H models have a 1/4 in. tapped opening for a pressure port at the top of the control.

When you install a gage into this pressure port, wrap two turns of Teflon thread sealing tape around the male threads of the gage. Overlap the tape half its width to make two layers. If you are using pipe sealant instead of Teflon tape, apply a generous amount of sealant to the male threads.

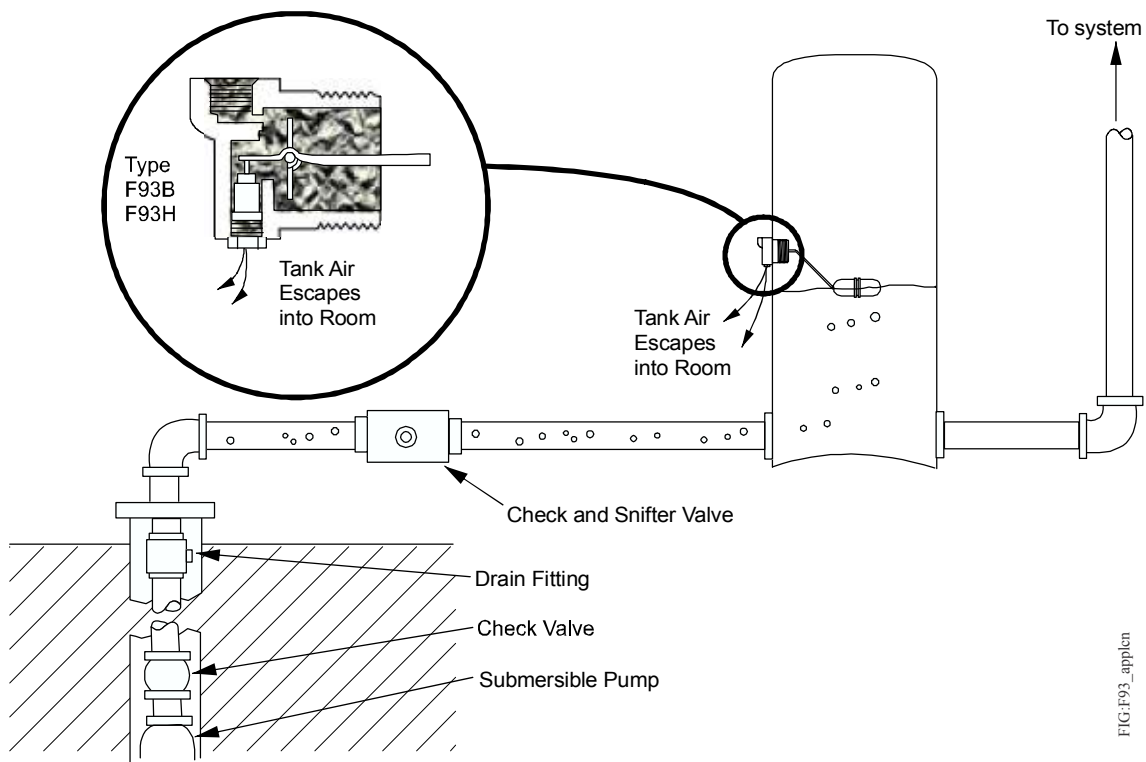

Figure 3: F93 Series Air Volume Control for Deep Well Application

If you do not install a gage, install a standard 1/4 in. pipe plug in the opening. Wrap two turns of Teflon thread sealing tape around the male threads of the plug or gage. Overlap the tape half its width to make two layers. If you are using pipe sealant instead of Teflon tape, apply a generous amount of sealant to the male threads.

Note: Do not overtighten. 5 lb-ft (6.8 N•m) of torque is adequate to seal the threads.

IMPORTANT: Do not use the gage opening to connect the pressure switch controlling the operating pump. It must only be used for a pressure gage because the opening can become plugged.

Setup and adjustments

On initial start up, the tank is full of air at atmospheric pressure. This allows the float to drop, holding the air valve in the open position. Pressure does not build up in the tank until sufficient water is pumped into the tank to raise the float and close the valve.

The volume of air stabilizes after several cycles.

If the pump short-cycles after several days of operation, the supply of air in the tank is insufficient. Open the air inlet valve on the pump so that more air can enter the system.

Air volume controls require no oiling or adjustments.

Checkout procedure

Before leaving the installation, observe at least three complete operating cycles to be sure all components are functioning correctly.

Ordering information

To order, specify the complete product code number.

Table 2: Selection chart for F93 Series Air Volume Controls for Deep Wells

Product code number	Description
F93A-1C	Air Volume Control for Deep Wells, opens on pressure drop, no gage tap, no pressure release valve
F93B-1C	Air Volume Control for Deep Wells, opens on pressure drop, 1/4-18 PTF SAE short gage tap, no pressure release valve
F93H-1C	Air Volume Control for Deep Wells, opens on pressure drop, 1/4-18 PTF SAE short gage tap, with 25 PSIG (172 kPa) minimum air pressure release valve. Use this model in applications where water may be rapidly drawn from the system.

Repair information

Do not make field repairs. Repair parts are not available. If an F93 Series Air Volume Control for Deep Wells malfunctions, replace the control. Contact your nearest Johnson Controls®/PENN® distributor or sales representative to purchase a replacement.

Technical specifications

F93 Series Air Volume Control for Deep Wells

Body material	30% glass-filled Noryl thermoplastic
Float material	Plastic with brass rod
Maximum tank pressure	100 psig (690 kPa)
Shipping weight	Individual: 0.19 kg (0.42 lb)
Tank connector size	1-1/4 in. Male NPT
Compliance	United States Federal Safe Drinking Water Act (SDWA) Compliant, Underwriters Laboratories Classified in Accordance with NSF/ANSI 372 (File MH59894)

The performance specifications are nominal and conform to acceptable industry standards. For applications at conditions beyond these specifications, consult Johnson Controls/PENN application engineering at 1-414-524-5535 or 1-800-275-5676. Johnson Controls shall not be liable for damages resulting from misapplication or misuse of its products. © 2018 Johnson Controls.



www.penncontrols.com

© Johnson Controls and PENN are registered trademarks of Johnson Controls in the United States of America and/or other countries. All other trademarks used herein are the property of their respective owners. © Copyright 2018 by Johnson Controls. All rights reserved.