

**SMART TEMP® UNIVERSAL
7-DAY PROGRAMMABLE THERMOSTAT
(FOR BOTH CONVENTIONAL AND HEAT PUMP SYSTEMS)**

INSTALLATION AND OPERATING INSTRUCTIONS

52133

IMPORTANT!

- Please read all of these instructions carefully before beginning installation.
- Label every wire terminal designation on your existing thermostat wiring before removing your old thermostat.
- Ignore the color of the wires since they may not comply with any standard. Please connect wires using the terminal letter designations.

Thank you for your confidence in our product. To obtain the best results from your investment, please read and follow the installation procedures carefully, and one step at a time. This will save you time and minimize the chance of damaging either the thermostat or possibly your heating and cooling system. These instructions may contain information beyond that which may be required for your particular installation.

SYSTEM COMPATIBILITY	2	COMPLETE THE INSTALL	19
FEATURES	3	FRONT PANEL ITEMS	19
TOOLS YOU MAY NEED	3	OPERATING INSTRUCTIONS	21
MOUNTING LOCATION	4	TEMPERATURE PROGRAMS	23
REMOVE OLD THERMOSTAT	4	ADVANCED FEATURES	24
INSTALL THERMOSTAT BASE	5	BATTERY REPLACEMENT	33
WIRING INFORMATION	5	TECHNICAL ASSISTANCE	33
CAUTIONS AND WARNINGS	6	LIMITED WARRANTY	34
WIRING DIAGRAMS	8	MERCURY NOTICE	34
HARDWARE SETUP OPTIONS	17		

WARNING: Use Energizer® or DURACELL® Alkaline Batteries Only.

Energizer® is a registered trademark of Eveready Battery Company, Inc.

DURACELL® is a registered trademark of The Procter & Gamble Company

P722U

Fan Mode
Switch

LCD Display Screen

Set Slide
Switch

System Mode
Switch

UP / DOWN Buttons

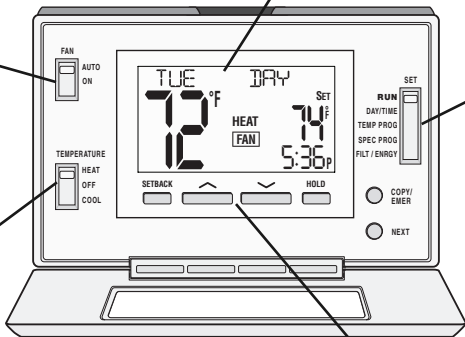

SYSTEM COMPATIBILITY:

The electrical rating for this thermostat is 1.5 Amps per terminal, with a maximum total combined load of 3.0A for all terminals combined.

COMPATIBLE WITH:

- Most 24-volt heating and cooling systems
- 1 or 2 stage Heat / 1 or 2 stage Cool: Gas, Oil or Electric systems
- 1 or 2 stage Heat / 1 or 2 stage Cool: Heat Pump systems
- 3-wire hydronic (hot water) zone valves
- Gas Millivolt heaters

NOT COMPATIBLE WITH:

- 120/240 VAC line-voltage systems (without a transformer), ask your LUXPRO dealer for thermostats to control these systems.

FEATURES:

- 1 or 2-Heat / 1 or 2-Cool, 7-day programming
- Universal Compatibility for all system types
- Each day of the week can be programmed separately
- Exclusive LUX® Speed Slide™ for easy programming
- User-selectable periods per day (2 or 4)
- User-selectable programmable or non-programmable operation
- LuxLight® EL (Electro-Luminescent) lighted display
- Energy usage monitor
- Special program feature
- Programmable air filter life timer
- Programmable keypad lockout for unauthorized users
- Manual temperature hold
- Adjustable vacation hold (1 to 30 days)
- Temporary temperature override
- Adjustable temperature differential / cycle-rate
- Adjustable 2nd heat stage Offset setting
- User temperature calibration
- Adjustable heat/cool set temperature limit stops
- Smart recovery
- Dual-powered (battery and/or 24-volt system powered)
- Battery-free memory storage
- F/C temperature display
- 12/24-hour clock display
- 5/2-minute selectable time delay for equipment protection

TOOLS YOU MAY NEED:

- Screwdrivers
- Wire Stripper
- Wire Cutter
- Drill with assorted drill bits (new installations only)

MOUNTING LOCATION:

On replacement installations, mount the new thermostat in place of the old one unless the conditions listed below suggest otherwise. On new installations, please follow these general guidelines:

1. Mount the thermostat on an inside wall, about 5 ft. (1.5m) above the floor.
2. Do not locate the thermostat where air circulation is poor such as in a corner, alcove, or behind a door that is normally left open.
3. Do not locate the thermostat where unusual heating or cooling conditions may be present, such as: direct sunlight, above a lamp, television, or radiator, or on a wall next to an exterior door or window.
4. Do not locate in a damp environment, as this can lead to corrosion that may shorten thermostat life.
5. If painting or construction work is still ongoing, cover the thermostat completely or wait until this work is complete before installation.

WARNING:

All wiring must conform to the local codes and ordinances that are in your particular location.

REMOVE OLD THERMOSTAT:

1. Turn OFF the electricity to all heating and cooling components. Do not turn the electricity back on until all work is completed.
2. Remove the front portion of your old thermostat to expose the wiring connections.
3. Write down the letters printed near each wire terminal that is used, and also the color of each wire that is connected to it. Self-adhesive wire labels are also enclosed.
4. Carefully remove the wires one at a time, and bend them in a manner so that they do not fall back inside the wall. Do not allow bare wire ends to touch each other.
5. Loosen the mounting screws for the old thermostat and carefully remove it from the wall.

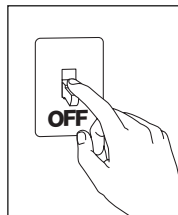

INSTALL THERMOSTAT BASE:

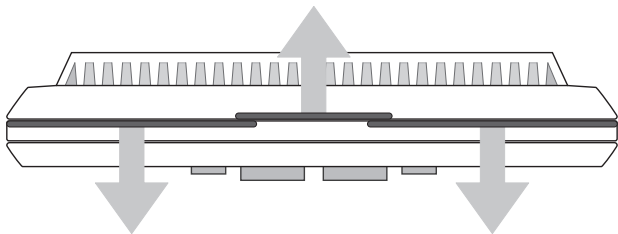

THERMOSTAT TOP VIEW

1. Strip wire insulation leaving only 3/8 in. (9.5mm) bare wire ends, and clean off any corrosion present.
2. Fill the wall opening with non-combustible insulation to prevent drafts from affecting the thermostat's normal operation.
3. Route the wires through the opening in the new thermostat base plate, and hold the base against the wall. Try to line up the screw holes from the prior thermostat, and install the mounting screws.
4. If the previous holes cannot be used, hold the thermostat base against the wall so that it appears straight and level (position the base for best appearance) and mark for the new screw holes. Attach the base to the wall using the screws provided (use the supplied plastic anchors if needed when mounting to a soft material such as drywall).

WIRING INFORMATION:

CONNECTING THE WIRES:

When attaching the wires to the thermostat, please ensure that the bare wire ends are held ALL the way into the terminal block while the screw is being tightened.

CAUTIONS AND WARNINGS:

- The thermostat requires batteries to operate and failure or sub-standard performance of the batteries may impair or prevent the correct operation of the thermostat. Use Duracell® or Energizer® alkaline batteries ONLY for all LUX thermostats requiring batteries. **BE SURE TO CHANGE THE BATTERIES AT LEAST ONCE A YEAR**, or whenever you see the LO BATT indication on the screen. Failure to follow these battery instructions could result in property damage and/or personal injury.
- The electrical rating for this thermostat is 1.5 Amps per terminal, with a maximum total load of 3.0A for all terminals combined.
- The thermostat contains parts that may wear out through use and are susceptible to failure if over-loaded or used in a manner other than as indicated in the documentation.
- Check unoccupied residences regularly to ensure that all systems are operating properly.
- Check any heating/air-conditioning system including this product before operation and at regular intervals.
- Electrical interference, static electricity, failure or substandard performance of batteries, wiring defects in the installation and/or characteristics of the connected HVAC devices may prevent the system from regulating heating and cooling as anticipated.
- The thermostat is a sensitive device and dropping the product can cause damage to critical components. If the product is dropped or shaken violently during transport or installation then it should be replaced immediately.
- Persons with physical or mental limitations may not be able to promptly respond to a malfunction of the heating/air-conditioning system.
- All residents should be made aware of the potential in any system for malfunctions that could cause continuous heating or cooling and should be familiar with the operation and location of the heating/cooling appliance on/off switch.
- Read the instruction manual completely before installing the thermostat. You should consult a qualified HVAC technician or an electrician if you do not fully understand the installation instructions.

WIRING DIAGRAM NOTES:

(Important, please read all notes before connecting wires)

- If the information provided in the following wiring diagrams does not clearly represent or match your system, please refer to the “TECHNICAL ASSISTANCE” section of this manual, and contact us ***before*** removing any of your existing thermostat wiring.
- All of the dashed wires shown in the wiring diagrams are either optional, or their usage depends upon your specific system type or brand. For example: Diagram #1 shows the fan wire as optional. If your system does not have a fan, than this terminal will not be used.
- Terminal letters shown in black represent typical wiring applications. Depending upon the brand of your specific system or thermostat, your terminal letters may not match exactly. Terminal letters shown in gray represent other possible wiring designations that you might see on your existing thermostat terminals.
- The optional “C” terminal is used for powering the thermostat by the 24-volt system, using the System Common wire. This can be used alone, or in addition to installing batteries as a backup. NOTE: connecting the System Common wire to the thermostat is not necessary for heating and cooling to function properly.
- If your old thermostat has both a “Y” and “C” wire both present, then “C” is most likely a System Common wire.
- For Heat Pump systems, you will use either the “O” terminal or the “B” terminal on this thermostat, but not both. If your old thermostat has both an “O” and a “B” wire present, then “B” is likely a System Common wire and may be connected to the “C” terminal. Connecting a System Common wire to this thermostat’s “B” terminal may damage the thermostat, and also your heating and cooling system.
- Some Heat Pump systems have a wire for AUX electric heat (usually W2), and also a separate wire for Emergency electric heat (usually E). This thermostat uses the W2 terminal for both AUX and Emergency Heat. Tape off your “E” wire, and confirm that all components function without it.
- If replacing an old thermostat that has a mechanical clock, there may be ***two*** wires labeled as “C” for the clock power. Tape off these wires and do not connect them to the “C” terminal of this thermostat.

WIRING DIAGRAMS:

DIAGRAM	SYSTEM TYPE / DESCRIPTION	PAGE #
#1	CONVENTIONAL: HEATING 1-STAGE OR 2-STAGE 2, 3, 4, 5 WIRES	8
#2	CONVENTIONAL: HEATING 3-WIRE ZONE VALVE 3, 4 WIRES	9
#3	CONVENTIONAL: COOLING..... 1-STAGE OR 2-STAGE 3, 4, 5 WIRES	10
#4	CONVENTIONAL: HEATING AND COOLING..... 1-STAGE 4, 5 WIRES	11
#5	CONVENTIONAL: HEATING AND COOLING..... 1-STAGE OR 2-STAGE 4, 5, 6, 7 WIRES	12
#6	CONVENTIONAL: HEATING AND COOLING..... TWO-TRANSFORMERS 5, 6 WIRES	13
#7	HEAT PUMP: HEATING AND COOLING..... SINGLE-STAGE ONLY 4, 5 WIRES	14
#8	HEAT PUMP: HEATING AND COOLING..... WITH AUX / EMERGENCY HEAT 5, 6 WIRES	15

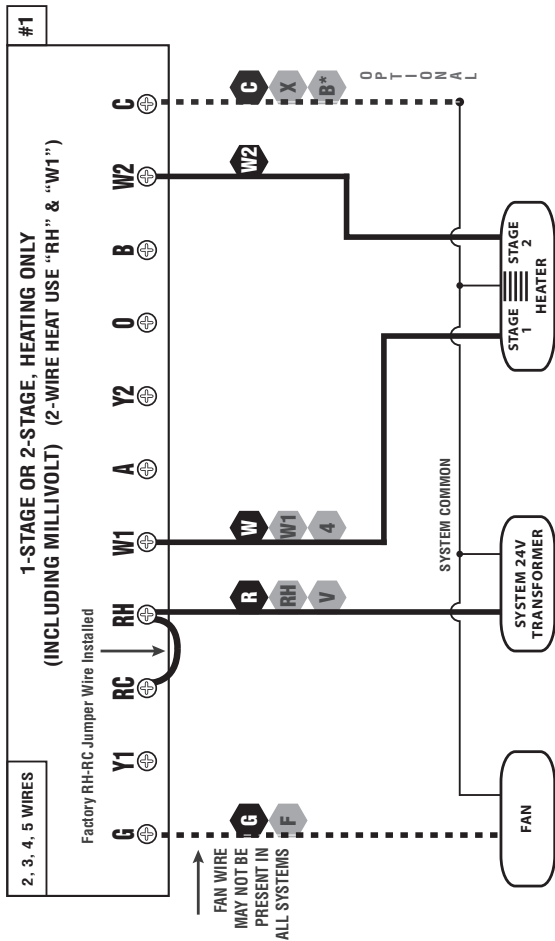

NOTE: THE BLACK TERMINAL LETTERS ARE TYPICAL, GRAY TERMINAL LETTERS ARE BRAND SPECIFIC

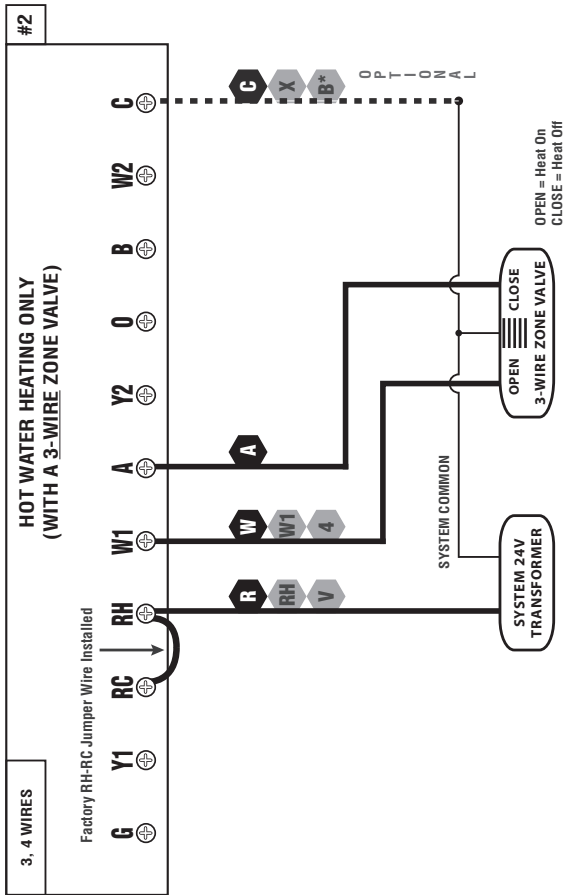

NOTE: THE BLACK TERMINAL LETTERS ARE TYPICAL, GRAY TERMINAL LETTERS ARE BRAND SPECIFIC

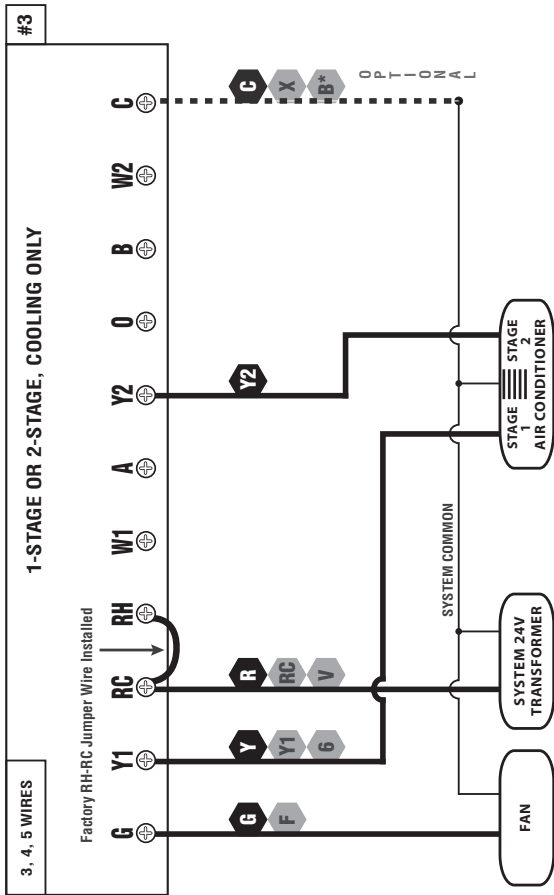

NOTE: THE BLACK TERMINAL LETTERS ARE TYPICAL, GRAY TERMINAL LETTERS ARE BRAND SPECIFIC

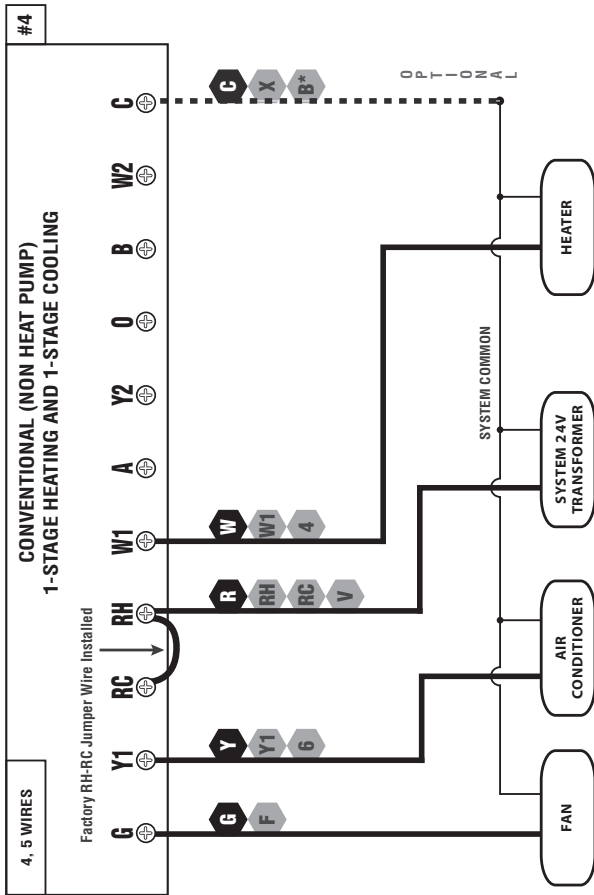

NOTE: THE BLACK TERMINAL LETTERS ARE TYPICAL, GRAY TERMINAL LETTERS ARE BRAND SPECIFIC

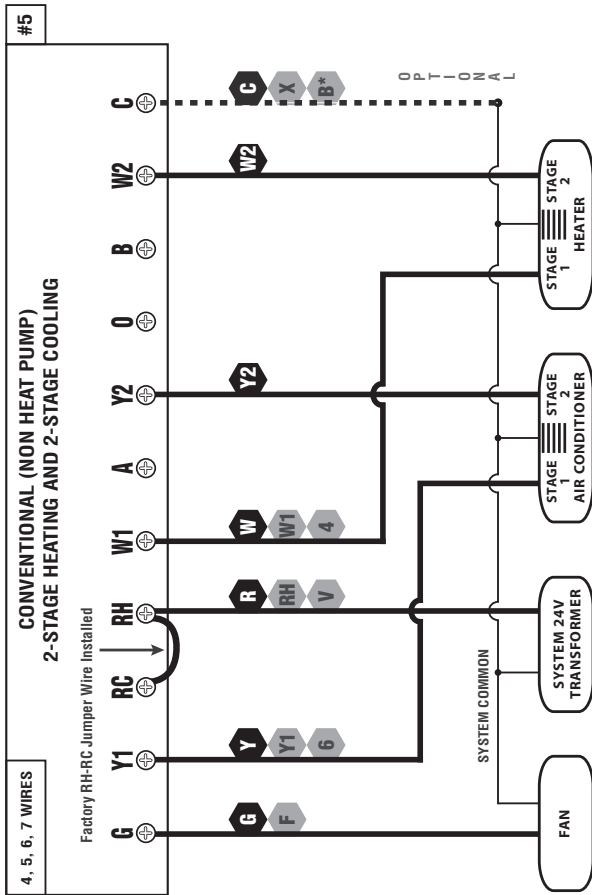

NOTE: THE BLACK TERMINAL LETTERS ARE TYPICAL, GRAY TERMINAL LETTERS ARE BRAND SPECIFIC

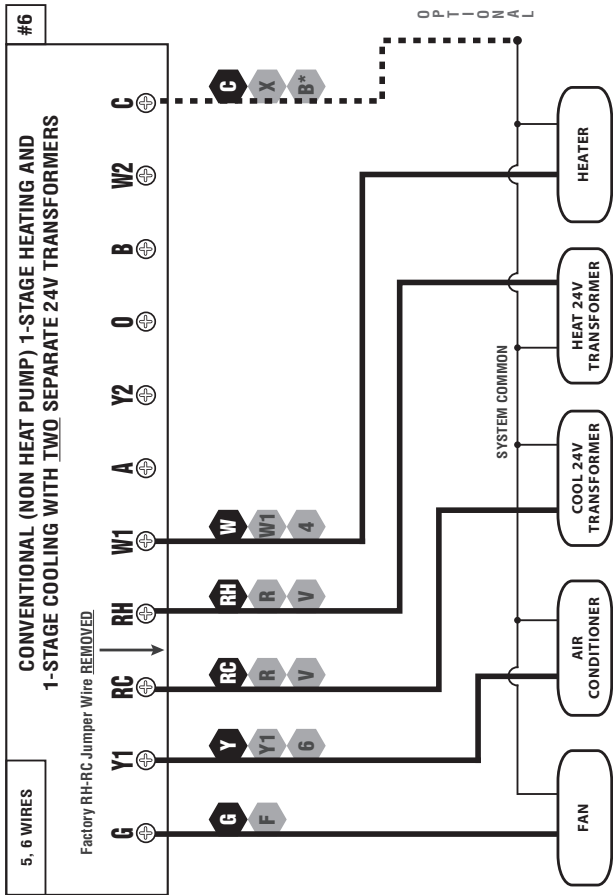

NOTE: THE BLACK TERMINAL LETTERS ARE TYPICAL, GRAY TERMINAL LETTERS ARE BRAND SPECIFIC

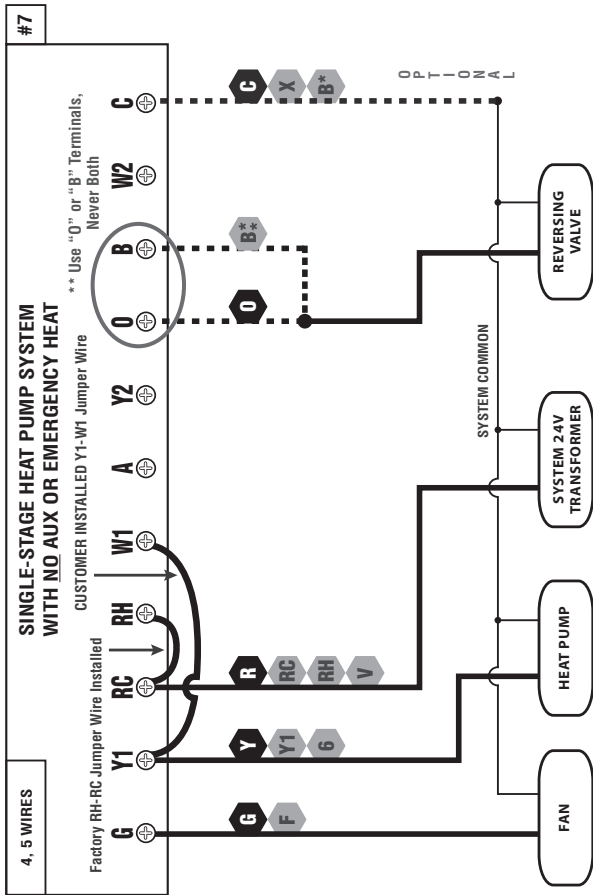

NOTE: THE BLACK TERMINAL LETTERS ARE TYPICAL, GRAY TERMINAL LETTERS ARE BRAND SPECIFIC

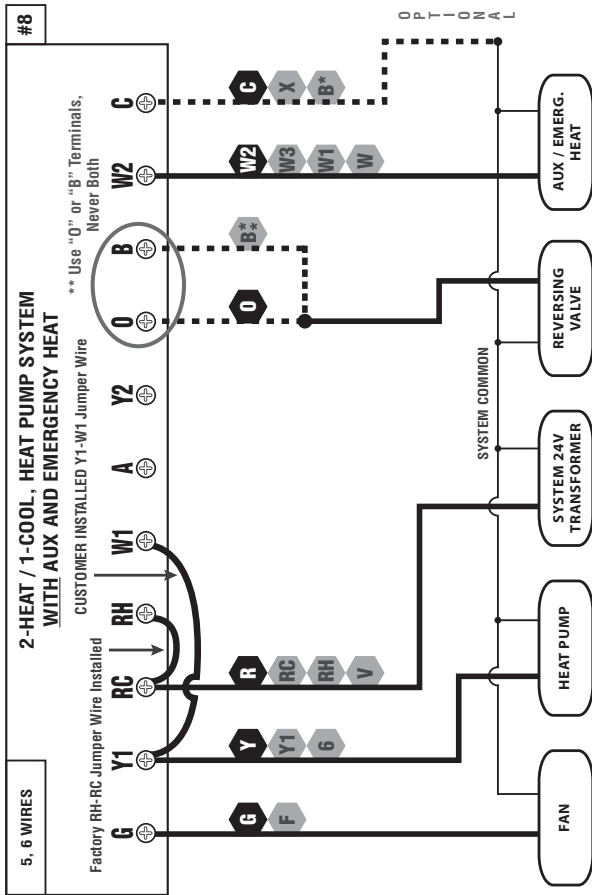

NOTE: THE BLACK TERMINAL LETTERS ARE TYPICAL, GRAY TERMINAL LETTERS ARE BRAND SPECIFIC

HARDWARE SETUP OPTIONS:

On the thermostat's circuit board, there is a row of DIP switches, labeled #1 through #9. The position of these switches will change how the thermostat operates, and also how information is conveyed to you on the LCD display screen. If you make any changes to these options, the changes are not recognized unless you either: change the position of the HEAT/OFF/COOL mode switch, or press the "HW RST" (Hardware Reset) button on the circuit board. The use of this button is further described in the "ADVANCED FEATURES" section of this manual.

These option switches are very small and should be moved carefully using objects such as: eyeglass screwdriver, fine-point pen, toothpick, or similar. The listing below describes the available choices for each option switch:



SWITCH #1 (SYSTEM): [OFF/DOWN = FURN, default] This setting is used for the majority of all heating systems that are not heat pumps. Examples for this setting would be: natural gas furnace, hot water baseboard heat, and oil heat. [ON/UP = HP] Use this setting if you have a heat pump unit (which looks just like an outside air conditioning unit, but is used for both cooling and heating).

SWITCH #2 (TYPE): [OFF/DOWN = PROG, default] The thermostat controls the room temperature by following temperature program periods that you set up based upon your daily routine. [ON/UP = MAN] The thermostat operates manually just like a mechanical or non-programmable model. This method of operation is very basic and only shows the room temperature and set temperature; there are no temperature programs, days of the week, or clock times.

SWITCH #3 (PERIODS): [OFF/DOWN = 4, default] The thermostat uses four temperature program periods in both heating and cooling (MORN, DAY, EVE, and NITE). Each period has a separate start time and a set temperature. [ON/UP = 2] The thermostat operates in the same manner as above, however there are only two temperature program periods for heating and cooling (DAY and NITE). This may be more convenient if you are typically home during the day, and only need the set temperature to be different while you are sleeping.

SWITCH #4 (SCALE): [OFF/DOWN = F, default] All temperature values are displayed using the Fahrenheit scale. [ON/UP = C] This setting displays all temperature values using the Celsius scale.

SWITCH #5 (TIME): [OFF/DOWN = 12 HR, default] This setting displays the clock times and temperature program period start time values on the screen using US standard AM and PM values. [ON/UP = 24 HR] This setting displays the clock and temperature program period start time values on the screen using the 24 HR military-time format (17:30 hours, 22:00 hours, without using AM/PM).

SWITCH #6 (DELAY): [OFF/DOWN = 5 MIN, default] This sets the minimum length of time that Heat or Cool must remain either On or Off, before it will automatically switch to the alternate On or Off state. This internal delay prevents rapid cycling of your system and provides equipment protection particularly for cooling units. The 5-minute setting is fine for most applications. [ON/UP = 2 MIN] If you feel that your system may need to cycle more frequently than the thermostat is allowing, then you may use the 2-minute setting.

SWITCH #7 (RECOVERY): [OFF/DOWN = DISABLE, default] The Early Recovery feature affects how the thermostat transitions from an energy saving setback (DAY and NITE) program period, to a comfort (MORN and EVE) program period temperature, when it is following the daily temperature programs. When this is disabled, the thermostat makes a set temperature change at the beginning of an upcoming period's start time. [ON/UP = ENABLE] The Early Recovery feature will calculate the capability of your system and turn on the heating or cooling early so that the temperature in your home reaches the desired set point as close as possible to the start of the period. During the time that the thermostat is performing a recovery, the words "IN RECOV" will be shown at the top of the display screen, alternating with the current DAY and PERIOD.

SWITCH #8 (BATTERY MONITOR): [OFF/DOWN = ON, default] This setting, regularly monitors the battery level, and shows “LOW BAT” on the screen if the batteries need to be replaced. Use this setting at all times when batteries are present in the thermostat. [ON/UP = OFF] This setting only applies if you are NOT physically using batteries in the thermostat, and are powering the thermostat entirely from the system (“C” wire terminal).

SWITCH #9 (FAN): [OFF/DOWN = GAS, default] This setting lets the heating system control the blower fan automatically by itself. Systems that would typically use the “GAS” setting would be: natural gas, propane, or oil furnaces. This setting has no effect upon Cool mode operation. [ON/UP = ELEC/HP] This setting runs the system’s blower fan when heat is called for, and is required for heating systems that do not control their own fan while the thermostat is in HEAT mode. Heat pump systems, and units with an electric heating element typically require this setting.

COMPLETE THE INSTALL:

Once the hardware options are set, install two new Energizer® or DURACELL® “AA” size alkaline batteries. Ensure that the batteries are installed in the proper direction as per the markings shown in the battery tray. If the batteries were already installed before changing the hardware setup options, change the position of the HEAT/OFF/COOL System Mode switch to accept the new hardware option switch settings.

FRONT PANEL ITEMS:

These items below are all located behind the door on the front of the thermostat. To open the door, pull outwards using the small indentation in the center of the top edge of the thermostat housing.

HEAT / OFF / COOL, SYSTEM MODE SWITCH: Set this switch to HEAT to control your heating system, and COOL to control your cooling system. The OFF position will disable both the heating and cooling units.

AUTO / ON, FAN MODE SWITCH: When this switch is in AUTO, the blower fan (if present in your system) will automatically cycle on and off by itself while heating or cooling is running. When in the ON position, the blower fan will run constantly with or without a demand for heating or cooling, even when the System Mode switch is in the OFF position.

NOTE: The Fan Mode switch only works if your system provides a wire for the thermostat's "G" wire terminal, to control a blower fan. The Fan Mode switch has no effect in systems that do not have a blower fan (such as a hot water radiator system).

MULTI-FUNCTION, SET SLIDE SWITCH: This switch provides an easy way to quickly access the most commonly used thermostat settings. This switch has 5 individual positions, and unless a specific setting is being adjusted, this switch should always remain in the RUN position for the thermostat to control the room temperature. The other Set Slide switch positions are described in greater detail in the ADVANCED FEATURES section. **NOTE:** this switch is only operable when the thermostat is in "Programmable" mode. When the thermostat is used in "Manual" control mode, all 5 of the switch positions will act like the RUN position, except the "FILT/ENRGY" position.

SETBACK BUTTON: This button activates and deactivates the SETBACK feature, which overrides the set temperature for an adjustable duration. This feature is described in greater detail in the ADVANCED FEATURES section.

UP / DOWN BUTTONS: The UP and DOWN buttons are used to adjust any item that can be changed by the user. Examples are the set temperatures, clock times, and days of the week. In many cases, an item may be flashing if it can currently be adjusted.

HOLD BUTTON: This button activates and deactivates the manual Temperature Hold feature, and is also used for activating and deactivating the Special Program feature. These features are described in greater detail in the OPERATING INSTRUCTIONS and ADVANCED FEATURES sections.

COPY / EMERG BUTTON: While setting temperature programs, this button allows you to quickly copy settings from one day to another. When in Normal Run mode, the usage of this button varies depending upon your specific system configuration. For heat pump systems, pressing this button enables your emergency heat function, which is described in greater detail in the OPERATING INSTRUCTIONS section. For conventional systems, there is no such thing as emergency heat, so this button will have no effect.

NEXT BUTTON: This button is mostly used while setting items such as software options, and temperature program periods. When there are several items on the screen that can be changed, usually one of them is flashing indicating that it can be adjusted. Pressing the NEXT button will cycle through which item is flashing.

OPERATING INSTRUCTIONS:

SET DAY AND TIME: Place the Set Slide Switch into the DAY/TIME position. With the day flashing, press UP or DOWN to set the day of the week. Press NEXT and the clock time will start flashing. Use UP or DOWN to set the time, making sure the AM/PM indication is correct. Holding the UP or DOWN buttons will make the clock digits scroll rapidly. Return the Set Slide switch to the RUN position when finished.

HEATING AND COOLING: Basic operation of your heating or cooling system can be obtained with the Set Slide Switch in the RUN position and choosing either HEAT or COOL on the System Mode switch. The temperature can be adjusted using the UP and DOWN buttons. When the thermostat is first powered up, it will follow a default temperature routine that is preset from the factory (shown below).

PERIOD	HEAT	COOL MODE
MORN	6:00 AM 70 °F (21 °C)	6:00 AM 78 °F (26 °C)
DAY	8:00 AM 62 °F (17 °C)	8:00 AM 85 °F (29 °C)
EVE	6:00 PM 70 °F (21 °C)	6:00 PM 78 °F (26 °C)
NITE	10:00 PM 62 °F (17 °C)	10:00 PM 82 °F (28 °C)

EMERGENCY HEAT: (Heat Pump Configuration Only). While in normal Heat mode with the Set Slide switch in the RUN position, one single press of the COPY/EMER button will activate Emergency Heat mode. A single press again will end Emergency Heat mode, and return back to normal Heat mode. While in Emergency Heat mode, the word “EMER” will also be shown in the middle portion of the display screen. If a power loss occurs while in Emergency Heat mode, the thermostat will continue to remain in Emergency Heat mode even after the power comes back on.

Emergency Heat mode will prevent the first stage of your heat pump system from turning on, and use only the “W2” heat terminal (Auxiliary Heat) as the primary heating source. This will not only prevent the heat pump from wasting energy if outdoor temperatures are too low to support efficient operation, but it could also prevent damage to the heat pump if outside temperatures are below the manufacturer’s recommendations. As every heat

pump has different operating characteristics, you should refer to your heat pump literature to determine when to disable the heat pump and run in Emergency Heat mode.

LCD DISPLAY BACKLIGHT: The display screen is lighted to assist viewing at nighttime, or in locations with low light levels. A press of any button on the front panel will light the display for approximately 10 seconds. Any button presses that occur while the light is on will reset the 10-second timer, causing the screen to remain illuminated for an additional 10 seconds.

TEMPERATURE OVERRIDE: While in Program RUN mode, the set temperature can be temporarily changed by pressing UP or DOWN. The set temperature will return to the programmed value stored in memory when the start time of the next upcoming program period is reached (Morn, Day, Eve, Nite). While a Temporary Override is in effect, the word "OVERRIDE" will be shown in the display screen. An Override may be cancelled moving the mode switch to OFF, then back to HEAT or COOL.

MINIMUM RUN TIME: The thermostat has a default internal time delay of 5 minutes between load-on and load-off activations to prevent heating or cooling system damage, which can occur from very frequent cycling. If heating or cooling does not turn on right away with a manual change in set temperature, please wait at least 5 minutes and the system should resume normal operation.

TEMPERATURE HOLD: A Temperature Hold is used for maintaining a fixed set temperature. Once a Hold is initiated, the thermostat will maintain the set temperature indefinitely. A Hold may be used for days, weeks, or even months at a time, as long as the thermostat has adequate power. To enter Hold mode: press the HOLD button one time and the word "HOLD" will appear in the display. To cancel a Hold, press the HOLD button one more time. If a complete power failure occurs during a Temperature Hold, the thermostat will continue to remain in Hold mode even after the power comes back on. NOTE: If you plan to leave the thermostat in Hold mode for an extended duration (unattended), it is advisable to install new Energizer® or DURACELL® "AA" size alkaline batteries prior to leaving to ensure reliable operation of your heating and cooling system.

STATIC NOTICE: This thermostat is protected against normal static electric discharges, however to minimize the risk of damaging the unit in extremely dry weather, please touch a grounded metal object before touching your thermostat.

TEMPERATURE PROGRAMS:

By default, this thermostat has 4 separate program periods for both Heat and Cool mode, they are: MORN, DAY, EVE, and NITE. Each period ends at the start time of the following period. The heat programs are set in HEAT mode, and the cool programs are set in COOL mode.

NOTE: If the thermostat is configured to use only 2 periods per day instead of 4 (HARDWARE SETUP OPTIONS), the thermostat will only use the DAY and NITE periods. The MORN and EVE periods will not be visible on the screen.

SET TEMPERATURE PROGRAMS: Move the Set Slide switch to the TEMP PROG position. Programming will start with Monday. Use the UP/DOWN buttons to adjust the start time for the MORN period, then press the NEXT button to advance. Use the UP/DOWN buttons to adjust the set temperature for the MORN period, then press the NEXT button to advance. Now adjust the start time and set temperature for the DAY period, pressing the NEXT button after each to advance. Continue with these same steps to adjust the start times and set temperatures for the EVE and NITE program periods.

When the NITE period is finished the thermostat will advance to Tuesday, with the MORN period start time flashing. Perform the same steps that you used for setting the Monday periods, pressing the NEXT button to advance through each flashing value. Return the Set Slide switch to the RUN position when you are finished.

PROGRAM COPY FEATURE: The Copy feature allows you to copy all of the program information from any one single day, to any other day of the week. To copy heat programs, the thermostat must be in Heat mode, and to copy cool programs, the thermostat must be in Cool mode. Emergency Heat (heat pump configurations only) uses the Heat temperature program. With the Set Slide switch in the TEMP PROG position, press the COPY/EMER button one time. The words "COPY PROG" will briefly appear on the screen and flash once, followed by "FRM" and "TO". Next to FRM, a day of the week will be flashing. Using the UP/DOWN buttons, select the day that you want to copy from. Press the NEXT button one time. Your "copy from" day should be on steady with the "copy to" day flashing. Use the UP and DOWN buttons to select the day that you would like to copy to. A single short press of the COPY/EMER button will perform the Copy, and the flashing "copy to" day will have advanced to the next following day. You may continue to perform short single presses of the COPY/EMER button to proceed with copying to the

remaining days, one after the other (specific days may be skipped by pressing the UP button to advance past them when they are flashing in the “copy to” location). To exit the Copy feature, and return to the regular temperature program screen, press and hold the NEXT button for more than 2 seconds. Return the Set Slide Switch to the RUN position when you are finished.

ADVANCED FEATURES:

TEMPERATURE SWING AND OFFSET SETTING: A thermostat works by turning your heating or cooling system on and off whenever the room temperature varies from the desired set-point temperature. The amount of this variation is called the swing. Generally your system should cycle on about 3 to 6 times per hour. A smaller swing number makes the system cycle more frequently, so the room temperature is more precise and constant. A larger swing number will make the system remain on for a longer duration each time and decreases the number of cycles per hour. There is only one Swing setting, and this determines the cut-in and cut-out points for both the first and second stages (if present), in both Heat mode and Cool mode.

NOTE: The Swing and Offset settings need to be performed in a timely manner, as the thermostat will timeout and automatically exit these adjustment screens after approximately 10 seconds without a button press.

TO CHANGE THE SWING SETTING: Ensure that the System Mode switch is in the OFF position and the Set Slide switch is in the RUN position. Press and hold the HOLD button for at least 5 seconds. The words “SET” and “SWING” will appear in the upper right corner of the screen, along with a single flashing digit. Use the UP/DOWN buttons to change the number value between 1 and 9 (0.25F to 2.25F, in 0.25F degree increments). Number 1 is the default setting. Press the NEXT button to accept the swing setting and proceed to the OFFSET setting.

TO CHANGE THE OFFSET: After the Swing value has been accepted, the words “SET” and “OFFSET” will be shown on the screen, along with a flashing digit. This setting is shown as a number of degrees, and is similar in nature to the Swing however this only effects the operation of the second (auxiliary) heating stage, if present. The setting range for Offset is from 0 to 9 degrees. When set to 0 degrees, the second heating stage is completely disabled while in regular Heat mode (Emergency Heat mode will still function

for heat pump configurations). An Offset value from 1 to 9 degrees will determine the number of degrees from the set point that will be required for the second heating stage to turn on. This setting can be used to conserve energy in situations where the second heating stage is more costly to operate when compared to the first stage.

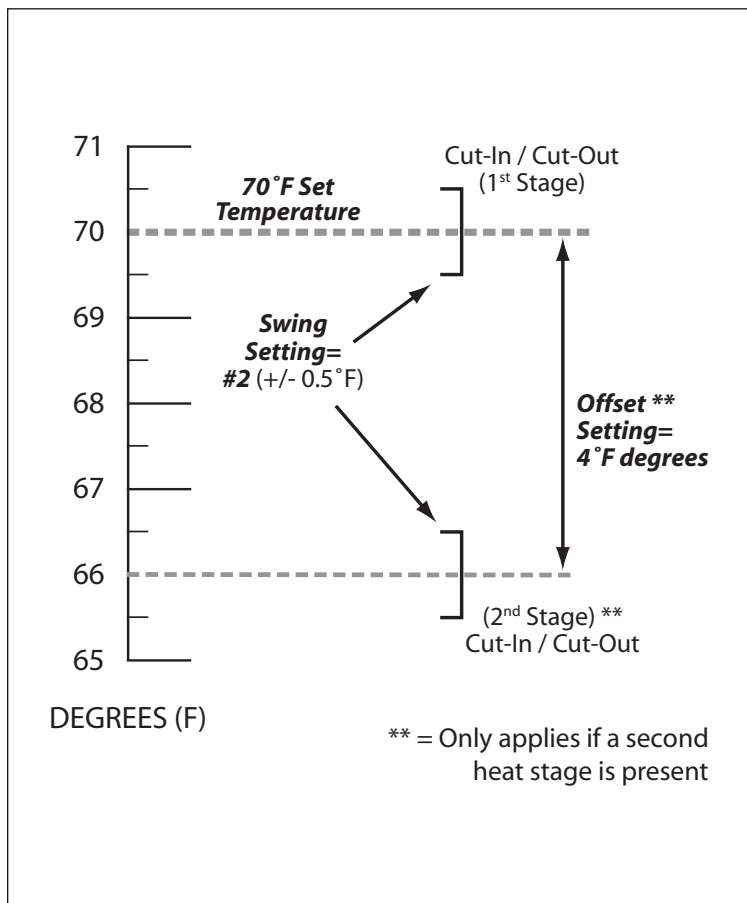

TEMPERATURE CALIBRATION: The internal temperature sensor in this thermostat is accurately calibrated at the factory, and in most cases alterations to this setting should not be needed. The Temperature Calibration feature allows you to manually offset the measured temperature by as much as plus or minus 5°F (3°C) degrees from its original value. This feature can be useful to match or synchronize this thermostat to another one or more, if multiple thermostats are used in the same home.

NOTE: The Temperature Calibration setting need to be performed in a timely manner, as the thermostat will timeout and automatically exit the adjustment screen after approximately 10 seconds without a button press.

TO CHANGE THE TEMPERATURE CALIBRATION: Ensure that the System Mode switch is in the OFF position and the Set Slide switch is in the RUN position. Press and hold both the UP and DOWN buttons together for at least 5 seconds. The words “SET” and “CAL” will appear in the upper right corner of the screen, along with a single flashing temperature digit. Use the UP/DOWN buttons to change the number of degrees of adjustment. 0° degrees is the default value, and means no correction is being applied. Press the NEXT button to accept the setting.

SETBACK FEATURE: The setback feature is similar to both a Temperature Override and a Temperature Hold, in that both are used to maintain a fixed set temperature instead of following a programmed daily routine. A Setback can be considered the same as a Temperature Override, which can last for a longer duration that you can adjust from 1-12 hours, or 1-30 days. By default, when a Setback is activated in Heat mode, the set temperature used will be 5F (3C) degrees lower than the current set temp. For Cool mode, the set temperature used will be 5F (3C) degrees higher than the current set temp.

TO START A SETBACK: Ensure that the System Mode switch is in either the Heat or Cool position, and that the Set Slider is in the RUN position. Press and hold the SETBACK button for at least 2 seconds. The screen will change and show the words “HOURS LEFT” and “OVERRIDE”, along with two digits. Use the UP/DOWN buttons to set the duration for how long you would like to maintain a fixed set temperature (from 1 to 12 hours). If you would like to set the duration for longer than 12 hours, keep pressing the UP button. The display will change from “HOURS LEFT” to “DAYS LEFT”, with an available duration of 1 to 30 days. Once your desired Setback duration is shown on

the screen, you can either wait for the screen to advance forward on its own, or press the NEXT button (behind the door) one time to jump ahead rapidly. Now use the UP/DOWN buttons to select your desired set temperature that will be used for the Setback duration. Just like the previous step, you can either wait for the screen to advance on its own, or press the NEXT button to advance and return to the Normal Run screen.

TO CANCEL A SETBACK: While in the Normal Run screen, press and hold the SETBACK button for at least 2 seconds. The word “OVERRIDE” will disappear from the screen and the Setback will be cancelled. Moving the System Mode switch or Set Slide switch, will also cancel a Setback.

SPECIAL PROGRAM FEATURE: The Special Program operates in the same manner as the normal heating and cooling programs do, however the Special Program activation is temporary, for a selected number of days (1-30). The Special Program period times and temperatures can all be set to different values to accommodate a wide variety of usage circumstances that may occur, such as: being home for a couple days instead of at work, or a vacation cut short. This feature eliminates the need to temporarily alter the normal temperature program settings that continue to be used most of the time. The heat Special Program is set in HEAT mode, and the cool Special Program is set in COOL mode. The “number of days remaining” counter decrements by one day, every 12:00 AM (Midnight).

NOTE: Just like the regular temperature programs, The Special Program has 4 separate periods for both Heat and Cool mode (MORN, DAY, EVE, and NITE). If the thermostat is configured to use only 2 periods per day instead of 4 (HARDWARE SETUP OPTIONS), the Special Program will only use the DAY and NITE periods. The MORN and EVE periods will not be visible on the screen.

TO SET THE SPECIAL PROGRAM VALUES: Move the Set Slide switch to the SPEC PROG position. The screen will display “S-PROG”. Use the UP/DOWN buttons to adjust the start time for the MORN period, then press the NEXT button to advance. Use the UP/DOWN buttons to adjust the set temperature for the MORN period, then press the NEXT button to advance. Now adjust the start time and set temperature for the DAY period, pressing the NEXT button after each to advance. Continue with these same steps to adjust the start times and set temperatures for the EVE and NITE program periods. Return the Set Slide switch to the RUN position when you are finished.

NOTE: When activating the Special Program feature, button presses need to be performed in a timely manner, as the thermostat will timeout and automatically exit the setting screen after approximately 10 seconds without a button press.

TO ACTIVATE THE SPECIAL PROGRAM: Press and hold the HOLD button for at least 5 seconds. The words “S-PROG” and “DAYS LEFT” will appear on the screen, along with a two digits. Use the UP/DOWN buttons to change the numbers for the desired number of days that you would like the Special Program to be used. Press the NEXT button to accept the setting and exit. While the Special Program is in effect, the clock time will alternate with the words “SPECIAL DAYS” and a two-digit value to indicate the amount of days remaining.

TO CANCEL THE SPECIAL PROGRAM: Press and hold the HOLD button for at least 5 seconds. The “SPECIAL DAYS” will stop alternating with the clock time, and the thermostat will now be in Normal Run mode.

TEMPERATURE LIMIT STOPS: There are two independent set temperature limit stops: a maximum heat set temperature, and a minimum cool set temperature. These stops do not prevent a user from performing normal actions like Temperature Override or Hold. The Heat Limit Stop prevents the set temperature from being adjusted higher than the heat limit setting. The Cool Limit Stop prevents the set temperature from being adjusted lower than the cool limit setting. Each of these temperature stops is user adjustable in one-degree increments, and these settings are protected by a selectable 2-digit code to prevent unauthorized tampering. By default, this 2-digit code is “00”, and the temperature stops can be used as-is with this code.

NOTE: The Temperature Limit Stop settings need to be performed in a timely manner, as the thermostat will timeout and automatically exit the setting screens after approximately 10 seconds without a button press.

TO SET THE HEAT LIMIT STOP: Place the System Mode switch in the OFF position, and the Set Slide switch in the RUN position. Press and hold the UP button while sliding the System Mode switch from OFF to HEAT. The words “CODE” and “T-STOP” will appear at the top of the screen, along with two digits. Use the UP/DOWN buttons to select the proper code to access the heat limit setting. Press the NEXT button to accept the setting. If the code you tried was not correct, the thermostat will exit and return to the Normal Run screen with no changes made. If the entered code is correct, the screen

will add the word “SET” and display the current heat set temperature limit. Use the UP/DOWN buttons to adjust the maximum heat set temperature value. Press the NEXT button to accept the setting and return to the Normal Run screen in heat mode.

TO SET THE COOL LIMIT STOP: Place the System Mode switch in the OFF position, and the Set Slide switch in the RUN position. Press and hold the DOWN button while sliding the System Mode switch from OFF to COOL. The words “CODE” and “T-STOP” will appear at the top of the screen, along with two digits. Use the UP/DOWN buttons to select the proper code to access the cool limit setting. Press the NEXT button to accept the setting. If the code you tried was not correct, the thermostat will exit and return to the Normal Run screen with no changes made. If the entered code is correct, the screen will add the word “SET” and display the current cool set temperature limit. Use the UP/DOWN buttons to adjust the minimum cool set temperature value. Press the NEXT button to accept the setting and return to the Normal Run screen in cool mode.

TO CHANGE THE TEMPERATURE STOP LOCK CODE:

IF YOU FORGET YOUR TEMPERATURE STOP CODE:

KEYPAD LOCKOUT: You can lock the front panel buttons to prevent unauthorized tampering of your thermostat settings.

NOTE: These keypad lock instructions need to be performed in a timely manner, as the thermostat will timeout and automatically exit the keypad lock screens and return to the Normal Run screen after approximately 10 seconds without a button press.

TO LOCK THE KEYPAD:

TO UNLOCK THE KEYPAD:

IF YOU FORGET YOUR KEYPAD LOCK CODE:

AIR FILTER MONITOR: In most systems that use a blower fan and air ducts, there is an air filter that is either replaceable or requires cleaning. The filter is usually located in the air handler, where the blower fan is. This thermostat feature assists you with keeping track of proper maintenance and/or periodic replacement intervals for your system's filter.

The Air Filter Monitor counts the duration of filter usage that has occurred, since the last time the Filter Monitor has been reset. This feature is for information purposes only, and does not affect the operation of your heating or cooling equipment, or the thermostat. When the filter usage duration has expired, the words "CHANGE FILTER" will appear at the top of the display screen, alternating with the current DAY and PERIOD.

TO SET THE AIR FILTER DURATION: Move the Set Slide switch to the "FILT/ENRGY" position. The words "FILTER LEFT" will be shown at the top

of the display screen. Press either of the UP/DOWN buttons to select the desired filter duration (in days) from the following choices: OFF, 30, 60, 90, 120, 180, or 365. If the filter duration value is set to “OFF”, then the Air Filter Monitor will be completely disabled.

TO RESET THE FILTER USAGE COUNTER: Move the Set Slide switch to the “FILT/ENRGY” position. The words “FILTER LEFT” will be shown at the top of the screen. Press both the UP and DOWN buttons together, and the usage counter will return to the beginning of the value that it originally started counting from. Refer to the previous paragraph, should you wish to change the starting value for the filter monitor. Return the Set Slide switch to the RUN position when you are finished.

ENERGY USAGE MONITOR: Your thermostat contains a timer, which records the amount of “on-time” for your heating and cooling systems. There are three records that can be displayed for both Heat and Cool modes:

- 1) The amount of system run time so far for today.
- 2) The amount of system run time for yesterday.
- 3) The total cumulative system run time since the timer was reset.

TO VIEW THE HEAT USAGE TIMERS: Place the System Mode switch in the OFF position, and the Set Slide switch in the FILT/ENRGY position. Press and hold the NEXT button while sliding the System Mode switch from OFF to HEAT. The words “TODAY USAGE” will appear at the top of the screen, along with the word “HEAT” and the amount of heating system runtime (displayed as “HH:MM”, for hours and minutes). Use the UP/DOWN buttons to cycle between Today’s Usage, Yesterday’s Usage, and the Total Cumulative Usage.

NOTE: For the Total Cumulative Usage, the timer will record up to a maximum of 99 hours and 59 minutes, then the display will change to “HHHH” for hours only, without the colon in the center. Return the Set Slide switch to the RUN position when you are finished.

TO RESET THE HEAT ENERGY USAGE: While viewing the Total Usage value, press and hold the HOLD button for at least 4 seconds. The usage should now be displayed as “00:00”. Return the Set Slide switch to the RUN position when you are finished.

TO VIEW THE COOL USAGE TIMERS: Place the System Mode switch in the OFF position, and the Set Slide switch in the FILT/ENRGY position. Press and hold the NEXT button while sliding the System Mode switch from OFF to COOL. The words “TODAY USAGE” will appear at the top of the screen,

along with the word “COOL” and the amount of cooling system runtime (displayed as “HH:MM”, for hours and minutes). Use the UP/DOWN buttons to cycle between Today’s Usage, Yesterday’s Usage, and the Total Cumulative Usage. NOTE: For the Total Cumulative Usage, the timer will record up to a maximum of 99 hours and 59 minutes, then the display will change to “HHHH” for hours only, without the colon in the center. Return the Set Slide switch to the RUN position when you are finished.

TO RESET THE COOL ENERGY USAGE: While viewing the Total Usage value, press and hold the HOLD button for at least 4 seconds. The usage should now be displayed as “00:00”. Return the Set Slide switch to the RUN position when you are finished.

HARDWARE RESET: The Hardware Reset button (labeled “HW RST”) is a small round push button that is located towards the right side of the circuit board, just below the battery holder. Pressing this button will cause the LCD display screen to become fully populated, the heating and cooling load relays to cycle off, read the position of the Hardware Setup Option switches, and will perform an internal system check of the thermostat components. If your thermostat appears to be acting in an erratic manner, pressing the Hardware Reset button may remedy this behavior. The temperature programs are not erased when a hardware reset is performed, however the clock will have to be changed to match the current day and time.

HW RST



SOFTWARE RESET: The Software Reset button (labeled “SW RST”) is a small round push button that is located towards the left side of the circuit board, just below the battery holder. A Software Reset is used to erase all heating and cooling temperature programs, and any user-adjustable software values such as: Swing, Offset, and Calibration, to their original factory default values. To perform a Software Reset, press and hold the Software Reset button for at least 5 seconds. The LCD display screen will become fully populated, then return to normal. The thermostat will still retain the current day and time even after a Software Reset has been performed.



SW RST

COMPRESSOR PROTECTION BYPASS: This optional feature permits the installer or service technician to temporarily disable the built in compressor protection delays. This is most useful for diagnosing and testing the heating and cooling systems after installation is complete, and should not be used during normal operation. To activate this feature, press and hold both the NEXT and HOLD buttons, while also perform a single press of the Hardware Reset button (the LCD display screen will become fully populated). Continue to hold the NEXT and HOLD buttons until the LCD display screen returns to normal. All compressor protection delays (in all modes of operation) will be disabled for 5 minutes. After the 5-minute duration has expired, the thermostat will return to normal operation automatically.

BATTERY REPLACEMENT:

This thermostat is powered by two “AA” Alkaline batteries. The batteries should be replaced AT LEAST once per year to ensure reliable operation (or sooner, if “-- -- LOW BATT -- --” appears at the top of the display screen). The batteries are located on the back of the thermostat, at the top of the circuit board. The front portion of the thermostat can be removed from the back half by pulling straight outwards on the top and bottom of the thermostat housing, at the large indentations that are present in the center of the top and bottom edges.

When installing new batteries, we recommend using only brand new Energizer® or DURACELL®, “AA” size alkaline batteries. Please observe the polarity markings shown in the battery compartment to ensure proper installation. When finished, line up the front of the thermostat to the base, and firmly press together to securely latch the front and back halves together properly.

TECHNICAL ASSISTANCE:

If you have any problems installing or using this thermostat, please carefully and thoroughly review the instruction manual. If you require assistance, please contact our Technical Assistance department at 856-234-8803 during regular business hours between 8:00AM and 4:30PM Eastern Standard Time, Monday through Friday. You can also receive technical assistance online anytime day or night at <http://www.luxproproducts.com>. Our website offers

you troubleshooting guides, answers to the most common technical questions, and also permits you to email your questions to our technical support staff at your convenience.

LIMITED WARRANTY:

If this unit fails because of defects in materials or workmanship within three years of the date of original purchase, LUX will, at its option, repair or replace it. This warranty does not cover damage by accident, misuse, or failure to follow installation instructions. Implied warranties are limited in duration to three years from the date of original purchase. Some states do not allow limitations on how long an implied warranty lasts, so the above limitation may not apply to you. Please return malfunctioning or defective units to the location from which the purchase was made, along with proof of purchase. Please refer to “TECHNICAL ASSISTANCE” before returning thermostat. Purchaser assumes all risks and liability for incidental and consequential damage resulting from installation and use of this unit. Some states do not allow the exclusion of incidental or consequential damages, so the above exclusion may not apply to you. This warranty gives you specific legal rights and you may also have other rights, which vary from state to state. Applicable in the U.S.A. and Canada only.

MERCURY WARNING AND RECYCLING NOTICE:

Mercury is considered to be a hazardous material. If this product is replacing a thermostat that contains mercury in a sealed tube, contact your local waste management authority for instructions regarding recycling and proper disposal. It may be unlawful in your state to place it in the trash.

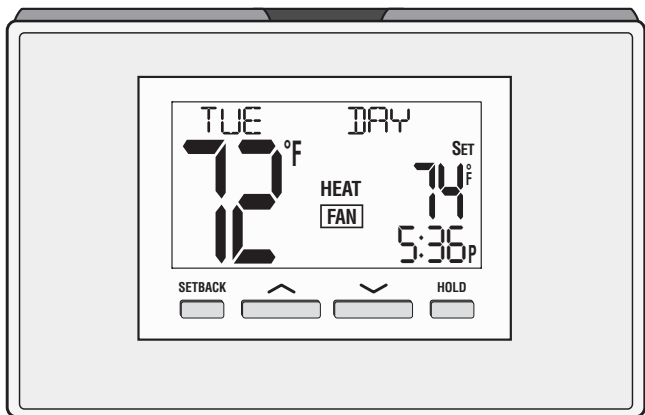

LUX  PRODUCTS
CORPORATION

Mt. Laurel, New Jersey 08054, USA
<http://www.luxproproducts.com>
856-234-8803